

Power Pulse Modulator

A Versatile Square Pulse Generator

Model: PWM-OCB

Type: Low Voltage, 8.5 A, 50V, 100 kHz

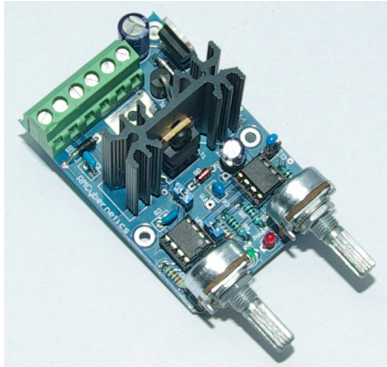

Features and Specifications

- Wide supply voltage range (12V – 30V)
- Switching voltage range from 0V to 50V
- Max output current 8.5A * continuous, 35A peak
- Low on-resistance of 0.045 ohms
- Frequency range 0.01 Hz to 100 kHz **
- Pulse width adjustable between 0% and 100%
- Compact design
- High quality double layer PTH, 2oz Copper PCB
- Dimensions: L69 x H44 x W46 mm (pots +21 mm)

* Max current varies with frequency due to switching losses. (See figure 0)

** Includes 2 capacitors for different frequency ranges. (See Table 2)

The **PWM-OCB** is an adjustable DC pulse generator designed for providing an easy way to adjust power to devices or to pulse them at a wide range of frequencies and pulse times. This version is designed primarily for use in low voltage circuits such as for electrolysis. The frequency is independently adjustable to the pulse width which can be varied smoothly from 0% to 100%. It is designed to fit a wide range of applications and be fully adjustable so that it can be used for many different tasks. These units can be linked together and used to complete a variety of tasks, or linked to our other circuits in all sorts of ways. The modules can also be linked together in a master/slave setup, and the pulse width (duty cycle) can be adjusted by an external analogue source. The circuit is made in England on a high quality PCB with double layer design, plated thru holes (PTH), and 2oz copper (twice as much as standard circuits) for durability and performance.

Example Applications

- LED or Light Bulb Dimming and Strobing
- Electrolysis and Electroplating
- Motor Speed Control
- Laser Pulse Experiments
- Hot Wire, or Heating Element Control.
- Tone Generator
- Shape Memory Alloy Control
- And more...

ELECTRICAL CHARACTERISTICS

NB: Figures may vary under different loading conditions and environments. Ratings are based on test conditions of 15V input and wire wound resistor load impedance of 1 ohms

Symbol	Parameter	Min	Max
V _{in}	Input Supply Voltage	12V ¹	30 V ²
V _{out}	Output Voltage	-	V _{in} - V _{drop}
V _{sec}	Secondary Switching Voltage	0 V	50 V
I _{sup}	Supply Current (no load)	30 mA	50 mA

I_{out}	Continuous Output Current	-	8.5 A
I_{pulse}	Pulse Current (1ms)	-	35 A
f	Frequency	0.01 Hz	100 kHz
t_{on} / t_{off}	Switching Speed (no load)	1.2 us / 2.2 us	1.5 us / 2.5 us
t_{on} / t_{off}	Switching Speed (load)	2 us / 5 ns	2.2 us / 8 ns
Z_{out}	Output Impedance	0.038 ohms	0.045 ohms
V_{drop}	Output Voltage Drop (varies with output current)	0.01 V	1.57 V
SIG _{out}	Signal Output (high)	9 V	12 V
SIG _{in}	Signal Input	0 V	12 V
PWM _{out}	PWM Control Voltage Output	3.5 V	8.3 V
PWM _{in}	PWM Control Voltage Input	3.5 V	8.3 V
FM _{in}	Frequency Modulation Voltage Input	1.7 V	12 V
OSC _{out}	Oscillator Output Voltage (high)	9 V	12 V

Table 1: Electrical Characteristics

¹ Units will still oscillate when powered by a supply voltage as low as 5V but the heating in the transistor will increase significantly (and therefore reduce current capacity) due to higher Z_{out}

² Input voltage is clamped by 5W, 30V Zener diode.

Power Ratings

Test conditions (See Fig 0b):

12V - 24V input, 1 ohm load (wire wound resistor) (R1), 1000uF power capacitor (Cp), schottky diode (D1).

The **PWM-OCB** continuous current rating is based on the temperature increase of the components. The ratings given are for the maximum average current possible before any component reaches 90°C..

To use the circuit at full power, you need to check against this graph the maximum current you can set for your working frequency. You may also need to fit a large capacitor at the input terminals to overcome any voltage drop in your power leads.

This graph is valid for the test conditions described. In your application, the performance may vary above or below what is shown here.

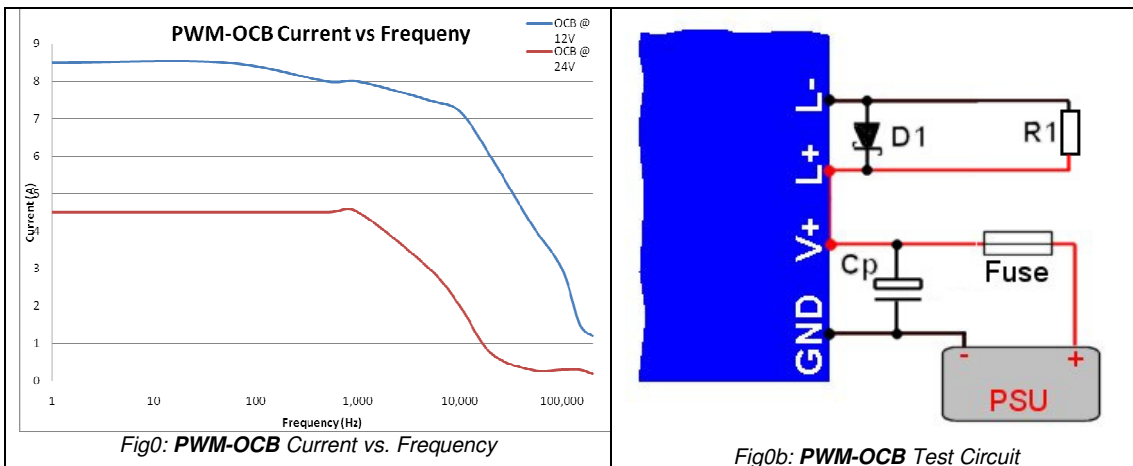

Connections

The main connections to the circuit are made using the 6-way terminal block at the end of the board. The input power (V_{in}) is connected to 'GND' and 'V+', while the load is connected between L+ and L-. See the diagrams below for how to connect a secondary supply. Some other connections such as OSC and FM can be made using the solder pads provided on the PCB. See the specs above and below for further details.

If you intend to pass large currents, ensure that the wire used is thick enough and that a sufficient capacitor is placed at the power input (see Fig0b). Always use a fuse to protect the circuit from accidental overloads or short circuits.

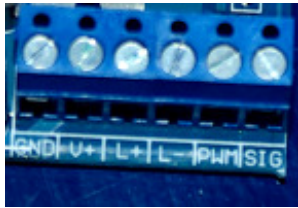

GND	Ground, Earth, 0V, or battery negative terminal.
V+	Input Supply Voltage, or battery positive terminal
L+	Load positive (internally connected to V+)
L-	Load negative
PWM	PWM Voltage In / Out
SIG	Signal In / Out

Fig 1a: Terminal Connections

Power Connections

Below you can see typical connections for the power supply and load. Make sure the cables are thick enough to carry the current you want to pass, and keep them short if possible. It is possible to use a single supply to power both the circuit and your load (see fig 2), or you can use a separate secondary supply for the load. This allows you to supply a different voltage to your load than what you are using to power the circuit. For the **PWM-OCB**, this secondary voltage can be from 0V to 50V.

Output Load Considerations

The minimum load impedance that should be connected to the device can be calculated using ohms law;

$$R_{LOAD} = V / I_{pulse}$$

For Example:

Using a 12V supply, $R_{LOAD} = 12 / 35 = 0.34$ ohms

If you are using long cables, install a fast diode as shown in fig 3.

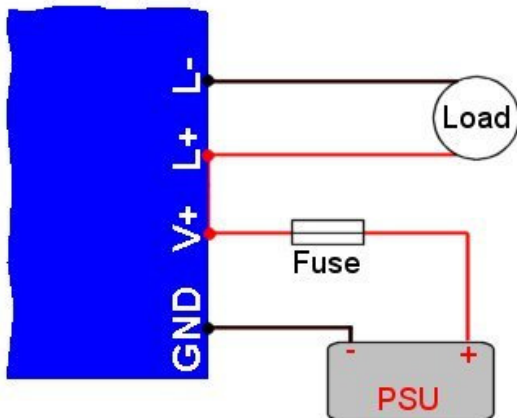

Fig 2: Typical power connections

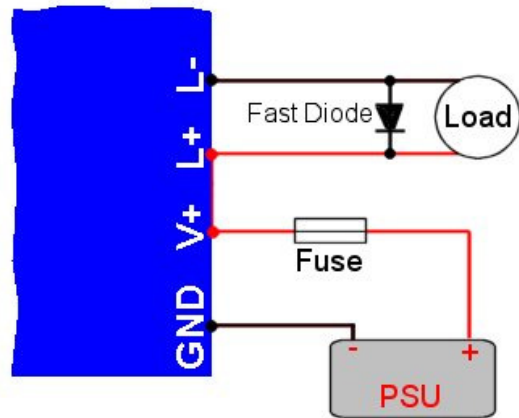

Fig 3: Typical power connections for inductive loads

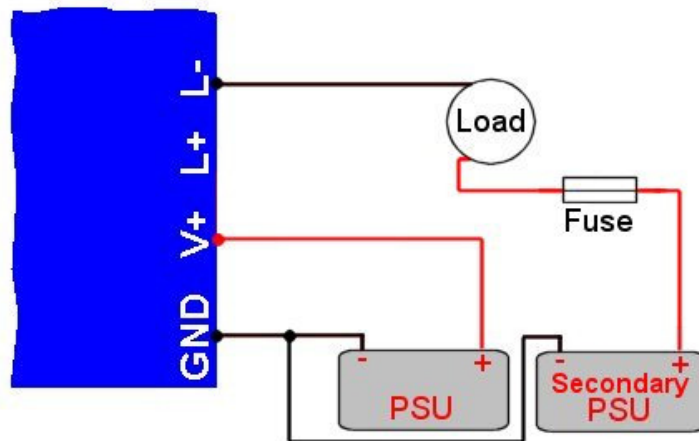

Fig 4: Typical power connections with secondary supply

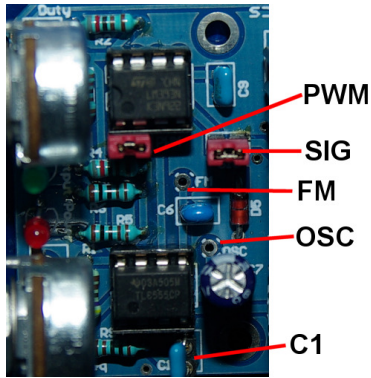

Fig 1b: Jumper & Solder Connections

Jumper Settings & I/O connectors

PWM *PWM voltage in/out*

The jumper shown as PWM can be used in a variety of ways for altering how the duty cycle (pulse width) is controlled. In its default position the pins are connected and duty control is done using the on board potentiometer. To control duty cycle with an external voltage the PWM jumper link is removed and the input voltage is applied to the 'PWM' terminal block connector. The output duty is inversely proportional to the input voltage.

SIG *Drive signal in/out*

The jumper SIG is used to set the 'SIG' terminal block connector as an input or output. With the SIG jumper link in place the device will function from the onboard signal and the 'SIG' terminal block connection can be used as an output. With the SIG jumper link removed, the device will require an external pulse signal to be applied to the 'SIG' terminal block connector. This connects directly to the transistor gate terminal and can therefore be driven with any waveform shape (0V to 12V DC). Note that sine or triangular waveforms will cause significantly more heating in the transistor and therefore reducing the current rating.

FM *Frequency modulation input*

This solder pad is for connecting an external control voltage for modulation of the output frequency. The voltage should be between 1.7V and 12V. When using the modulation input, the output duty will also increase when the frequency increases.

OSC *Oscillator output*

This is the square wave output from the oscillator. It can be used as a reference signal for monitoring frequency as the output is not affected by the duty setting.

C1 *Timing capacitor*

This socket allows you to fit the timing capacitor of your choice. See table 2.

Important Usage Notes

- Always make sure the pulse width is set to minimum (pot turned fully anti-clockwise) before connecting the circuit to a load or power source.
- Use a fused power supply to protect from accidental short circuit or overload. The fuse should be rated to suit your application and up to a maximum of the units specified pulse current. Use a quick blow type fuse.
- The heat generated in the switching transistor will vary with your loading conditions and the settings for frequency and pulse width.
- When driving high power loads, always check the temperature of the heat sink after making any adjustments.
- Consider the stray inductance of any power leads as this can generate significant voltage spikes due to the high current square pulses. The unit has some built in protection, but you must ensure you add adequate protection if necessary.
- Ensure an adequate power capacitor is fitted between V+ and GND if you are using a single power supply. *See Figure 0.*
- Do not remove the timing capacitor C1 when the unit is powered on.
- When using voltages above 30V or when driving high voltage coils, you should make sure the GND connector and the metal parts of the control pots are suitably earthed for safety. Failure to do this risks damage to the circuit and and/or electric shock.

Controls

The frequency and duty cycle can be independently adjusted using the potentiometers labelled ‘f’ and ‘%’. The frequency is adjusted with ‘f’ while the pulse width can be adjusted with ‘%’. Turning the control clockwise will increase the value corresponding function. The frequency range of the device depends upon the capacitor value of C1. The pre-fitted capacitor is 1nF which gives a range of medium frequency pulses which are suitable for most applications. Replacing C1 with a larger value capacitor will give a range of lower frequencies. At very low frequencies the green output LED will flash for a time that is proportional to the frequency and pulse width setting.

Capacitor Values for C1 and Corresponding Frequency

By fitting different sized capacitors into the socket marked C1, a wide range of frequencies can be achieved. The table below gives some example values and the frequency range produced. You can use any other capacitance you desire to get other frequencies. Note that the values shown will allow the unit to oscillate above the specified frequency range, but these are for reference only. As the frequency increases, the output will become more rounded and the transistor may not switch fully on during each pulse. This can lead to excessive heating which could potentially damage the unit. Using the device above its rated top frequency is done at your own risk. See Fig0 for how frequency affects heating.

Capacitance	Min Frequency	Max Frequency
1uF	1Hz	200Hz
0.47uF	1.5Hz	400Hz
0.33uF	2Hz	600Hz
220nF	3Hz	1kHz
10nF	219Hz	21kHz
1nF	710Hz	175kHz
220pF	3kHz	546kHz
100pF	6kHz	925kHz
22pF	19kHz	1.7MHz

Table 2: Capacitor values for frequency ranges.

Driving Inductive Loads (Motors, Solenoids, Transformers, Relays, Coils, etc)

The PWM-OCB has only basic protection against high voltage transients from inductive loads. When driving inductive loads you should take extra measures (detailed below) to protect the OCB from high voltage transients. This unit is **not** suitable for use with ignition coils. You should use the other more advanced models such as the OCBI, or OCXI for such loads.

Place a fast diode such as a schottky diode in parallel with the load input terminals as close to it as possible. If you are using a switch to reverse the direction of a motor, the diode should be placed just before the switch, between the switch and the OCB. See *figure 3*.

LED Indicators

The power LED lights to indicate that power is present in the signal generation circuitry. This can also be used to indicate the overall health of your input power supply. If the LED dims when the PWM output is high, this indicates your power supply is struggling to provide enough current. This could mean a low battery or overloaded PSU. Note that running the unit in these conditions may cause it to overheat.

The output LED lights when the switching transistor is on and power is being delivered to the outputs. At low frequencies you will see it flashing, at high frequencies it will appear to be on with a brightness proportional to the duty setting.

Linking Modules

Multiple units can be linked in a number of different ways. A master/slave arrangement can be used so that both units pulse together or at different times and rates. The diagrams below show how to link modules together. The connections for power and load are not shown for simplicity. It is assumed each module is connected to one or more power sources. A load can be connected to an individual module, or all modules can drive a separate load each. Any changes to the jumpers and links should be done with all power switched off.

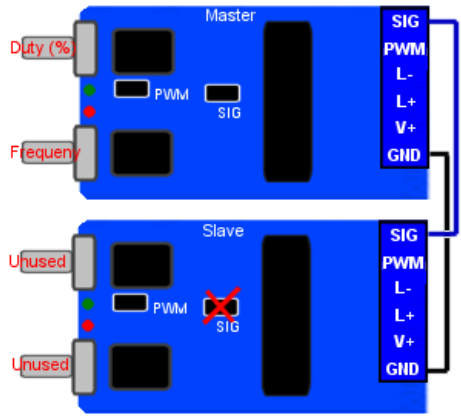

Master controlled Frequency and Duty

Modules linked in this way will all output the same frequency and duty which is set by the controls on the master device. You can have any number of slaves in this setup, but each added slave will reduce the switching speed and therefore increases heating in the transistors.

The 'SIG' terminal connector from each module should be linked via a short wire and the jumper links marked 'SIG' removed from the slave devices.

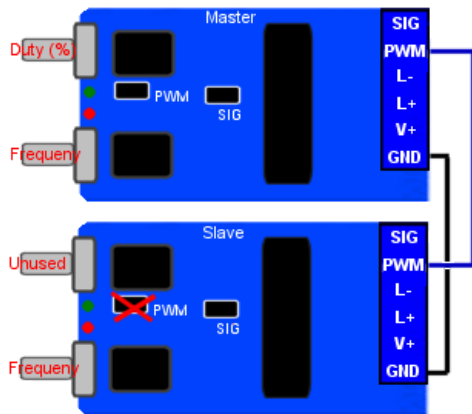

Master controlled Duty with independent Frequency control

Modules linked in this way will have independent frequency control while the duty percentage is controlled by the master device.

The 'PWM' connectors of two or more units are linked and the jumpers marked 'PWM' are removed from whichever modules are to be a slave.

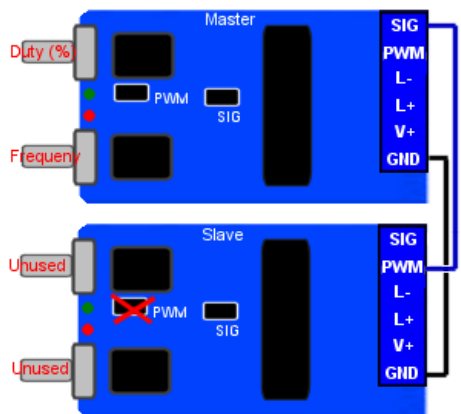

Master Frequency and Duty with Opposite Phase

Two modules linked in this way will have the same output frequency but each signal will be of opposite phase. This means that when the output of master devices is on, the output of the slave device will be off and visa-versa. Changing the duty setting using the master control will alter which module is on longest. It can be adjusted fully between 50% each to either module having 100% while the other has 0%.

The 'SIG' connector of the master device is connected to the 'PWM' connector of the slave device and the jumper 'PWM' is removed.