

# High Power Pulse Modulator

A Variable Square Pulse Generator

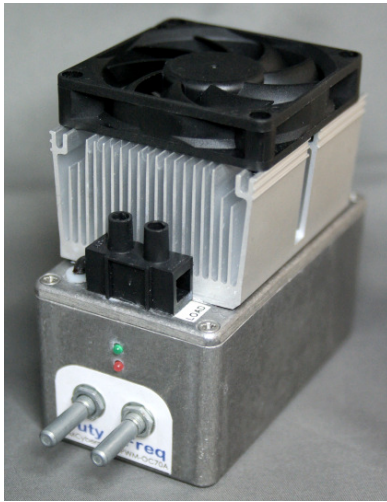

Dimensions: L114 x W64 x H114 mm  
(control posts L+25mm)

## PWM-OC70A – rev0808

This is a multifunction variable pulse generator. It is designed to fit a wide range of applications and be fully adjustable so that it can be used for many different tasks. These were designed with the primary application of electrolysis in mind.

This pulse width modulation circuit offers a highly compact and efficient way of controlling power delivery to any suitable load. The power density of these units make them great for projects where space may be important such as when the unit needs to be fitted in a car.

The two controls on the front of the unit are for controlling the duty (pulse width) and frequency. The variable duty gives you an easy way to control the power flowing to a load such as an HHO electrolysis cell. There is also a simple facility so that an external control knob for duty can be mounted externally. This allows the main unit to be installed anywhere while having the power control on a separate control panel such as a car dashboard.

Please read this manual carefully before using the device.

## Package Contents

PWM-OC70A unit  
Timing Capacitors

## Features and Specifications

NB: Figures may vary under different loading conditions and environments.

Fully adjustable square wave output  
Includes optional external power control knob (duty) and output indicator  
Output Frequency range - < 1 Hz to 300 kHz \*  
Output Duty cycle (pulse width) - 0% to 100%  
Supply Voltage - 12V to 15V DC  
Supply Current - up to 1.5A (no load)  
Dual power output  
Output A - 50A Continuous\*\*, 300A peak (1ms Tc 25 C)  
Output B - 1A continuous, 10A peak (1ms Tc 25 C)  
Switching Voltage A – 0V - 300V  
Switching Voltage B – 0V - 50V  
Enclosed in rugged Aluminium box for RF shielding and stability.

**Customisation options available ([email us your requirements](#))**

\* Frequency is adjustable in ranges determined by the fitted timing capacitor. Unit is shipped with one for low frequencies pre installed and is supplied with a set of others for the full frequency range.

\*\* Current capability depends on ambient temperature, airflow, and other operating conditions. The unit is tested for 50A continuous current in open air at room temperature with 100% duty.

## Connections

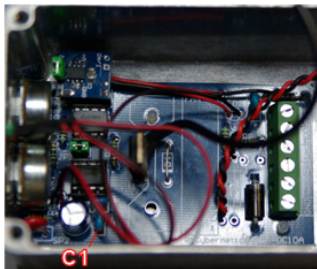

The connections for power, control signals, and output B are made after removing the lid to access the internal connections. The timing capacitors can be fitted to the position marked C1

The input power is connected to 'GND' and 'V+' at the green terminal block. This should be a 12V to 15V DC regulated power source. You should ensure that the power supply used is suitable for your application. If the voltage supply to the unit falls below 12V the fan may be too slow to cool it enough to run at full power. Care should also be taken to avoid voltage spikes on the power supply to the unit. Ideally the unit should be powered from a separate regulated supply.

The L+ and L- connectors (output B) are optional and can be used to power a secondary small load such as a small motor, light bulb or LED. The most common use is for powering an LED, moving coil meter, or similar device for indicating the output power level of the system.

When making connections to the terminal block it is important to make sure a good connection is made and that the wires are well gripped with no bare wire showing. This is essential to avoid accidental short circuits.

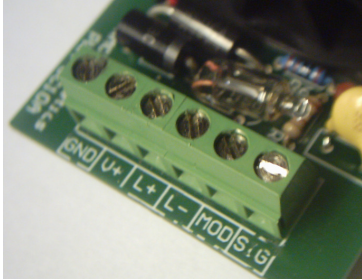

GND	Ground, Earth, 0V, or battery negative terminal.
V+	Input Voltage 12V to 15V
L+	Small load or indicator positive
L-	Small load or indicator negative
MOD	Modulation Voltage In/Out
SIG	Signal In / Out

**Connecting the load**

First of all, make the connections for powering the internal electronics as described above. The connections for the high power load (output A) are made using the large terminal blocks on the top of the box. These connections should be made using thick cable with a thickness suitable for the current you want to pass through them. This unit is very powerful and will easily melt cables if they are too thin. Cables should not be getting hot when in use, if they are becoming hot then this is a sign that they are too thin for your application. You should also use a fuse rated to protect your load or up to a maximum of 70A.

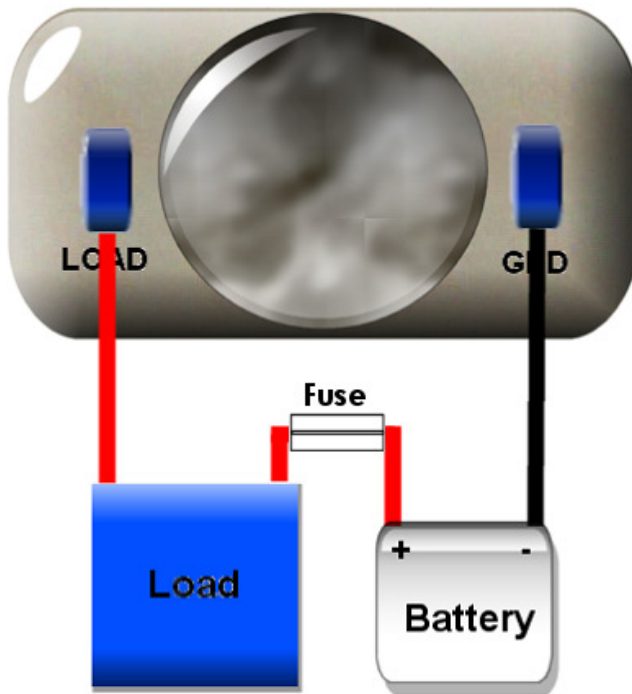

Connect a cable from the ground, negative terminal, or 0V connection of your battery or power supply to the large terminal block marked GND. This connector is internally linked to the GND of the power input to the circuit and to the metal case of the device.

The connector marked LOAD should be connected to the negative terminal of your load such as an electrolysis cell. The positive connector of your load should be connected to the positive of your battery or power supply. The voltage to the load can be upto a maximum of 300V

When making these connections make sure that the power input to the circuit is disconnected or switched off.

**External Control and Output Indicator (sold seperatley)**



The external control allows for remote operation of the duty setting of the device. This is ideal for situations such as in-car hydrogen generation, as the unit can be mounted under the bonnet while the control for the gas production rate can be mounted in a suitable position on the dashboard. The output indicator LED lights with a brightness that is proportional to the power output.

To use this control and disable the main control, remove the jumper from the PCB marked JP1. Alternativleyou can leave this jumper in place and you

should adjust the main duty control to about 50% so that the external control can adjust the full range. If you want to prevent the external control from being able to set the output to 0% or 100% you can use the main control to set this limit.

The cable is a 2m long (approx) shielded cable which can be cut to length. The connections are made using the terminal block inside the metal case of the main unit. Three wires plus the shield braiding need to be connected for proper operation and the fourth wire (yellow) is spare for use in other custom applications.

Wire Colour	Connector
Shield Braid	GND or metal case
Red	V+
Green	L-
Blue	MOD
Yellow	Unconnected

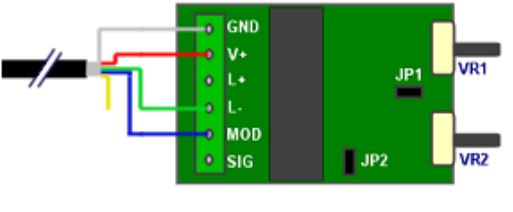

The LED can be replaced by any alternative power indicator such as a moving coil panel meter or LCD display. The power to the LED is just a copy of the pulse width modulated signal on the output and therefore indicates average power.

The spare yellow wire is for custom uses such as connecting to an AM-Adaptor (sold separately) for audio modulation from a car stereo. Other examples might be some connection to a temperature monitoring circuit in the box, or as a control signal to a relay for activating the PWM circuit.

### Important Usage Notes

Before connecting the circuit to a load or power source always make sure the pulse width is set to minimum (knob turned fully anti-clockwise) and the frequency is set high enough so that individual pulses can't be seen. Power the unit without power to the load first if you are not sure that the duty and frequency are correct. Use a fused power supply to protect from accidental short circuit or overload. The fuse should be rated to suit your application. The heat generated in the switching transistor will vary with your loading conditions and the settings for frequency and pulse width. **When driving high power loads, always check the temperature of the heatsink** after making any adjustments. If you will be installing the PWM unit somewhere like in a car, you should test it with your load in a situation where you can monitor the temperature. Be aware that reduced airflow will cause the device to run hotter.

### Controls

The frequency and duty cycle can be independently adjusted using the potentiometers labelled VR1 (Frequency) and VR2 (Duty). The frequency **range** of the device depends upon the capacitor value inserted into the socket marked C1 on the PCB. The pre fitted capacitor gives a range of low frequency pulses which can be seen on the output LED (LED2). Replacing C1 with a smaller value capacitor will give a range of higher frequencies. At high frequencies LED2 will appear to have a brightness that is proportional to the pulse width setting.

### Jumper Settings – I/O connectors

The jumpers JP1 and JP2 are used to set the status of the 'MOD' and 'SIG' connectors. With the jumper links in place (default), the 'MOD' and 'SIG' can be used as outputs while removing the jumper links causes them to act as inputs. When set as inputs the onboard manual adjustment of the relevant controls is disabled.

The voltage ratings for the I/O ports are to be kept within the voltage of the supply to the V+ connector. A 100 ohm resistor is recommended for protection when connecting to custom external devices.

The jumper JP1 can be used in a variety of ways for altering how the duty cycle is controlled. In its default position the pins are connected and duty control is done using the on board potentiometer. To control duty cycle with an external voltage the jumper JP1 is removed and the input voltage is applied to the 'MOD' connector. The output duty will be inversely proportional to the voltage applied to the MOD connector.

The jumper JP2 is used to set the 'SIG' connector as an input or output. With JP2 connected the device will function from the onboard signal and 'SIG' can be used as a signal level output. With JP2 removed the device will require an external signal to be applied to the 'SIG' connector. More information about linking modules together can be found on the next page.

## LED Indicators

LED1 (red) lights to indicate that power is present in the signal generation circuitry. This can also be used to indicate the overall health of your input power supply. If the LED dims when the PWM output is high, this indicates your power supply is struggling to provide enough current. This could mean a low battery or overloaded PSU. LED2 (green) indicates that the output power is active. It will either flash when used at very low frequency, or will have a brightness that is proportional to the duty setting.

## Example Applications

### Hydrogen Production (Electrolysis)

Simple control over reaction rates with PWM control. The easy to adjust power output is great for getting the gas production rate as needed. Frequency control allows for matching the pulses to resonant systems for optimum efficiency. External control knob and indicator make remote operation simple.

### Pulse Width modulation (PWM) Motor Speed Control

Pulse Width Modulation (PWM) is used to accurately control the speed of DC motors. The pulse frequency can be adjusted to match your motor for performance or reducing noise.

### Dimming or Flashing of LED's and Light bulbs

This module can be used to smoothly dim lights or make them flash at regular intervals. The brightness is adjusted by a pulse width modulated signal which can be set to an inaudible frequency.

### Tone Generator for small or large speakers

This circuit generates an adjustable square wave signal that is powerful enough to drive anything from piezoelectric sounders to large bass speakers. The frequency range can be adjusted between sub bass and ultrasonic levels.

## Capacitor Values and corresponding frequency

By fitting different sized (non-polar) capacitors into the position marked C1, a wide range of frequencies can be achieved. The table below gives some example values and the frequency range produced. You can use any other capacitance you desire to get other frequencies

Note that the values shown will allow the unit to oscillate above the specified frequency range, but these are for reference only. Above 100kHz the output will become more rounded and the transistor may not switch fully on during each pulse. This can lead to excessive heating which could potentially damage the unit. Using the device above its rated top frequency is done at your own risk.

Capacitance	Min Frequency	Max Frequency
220nF	3Hz	600Hz
47nF	14Hz	2.5kHz
10nF	71Hz	10kHz
1nF	710Hz	87kHz
470pF	1.5kHz	170kHz
100pF	6kHz	263kHz
47pF	10kHz	870kHz

## Linking Modules

Multiple units can be linked in a number of different ways. A master/Slave arrangement can be used so that both units pulse together or at different times and rates. The diagrams below show how to link modules together. The connections for power and load are not shown for simplicity. It is assumed each module is connected to the same power source. A load can be connected to an individual module, or all modules can drive a separate load each. Any changes to the jumpers and links should be done with all power switched off.

Connections are made using the terminal block inside the metal case.

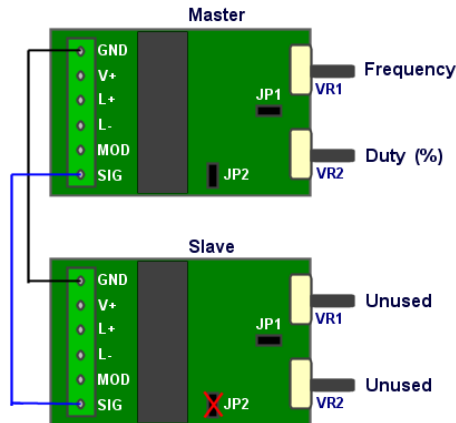

### Master controlled Frequency and Duty

Modules linked in this way will all output the same frequency and duty which is set by the controls on the master device. You can have any number of slaves in this setup.

The 'SIG' connector from each module is joined together and the link jumper JP2 is removed from whichever modules are to be a slave.

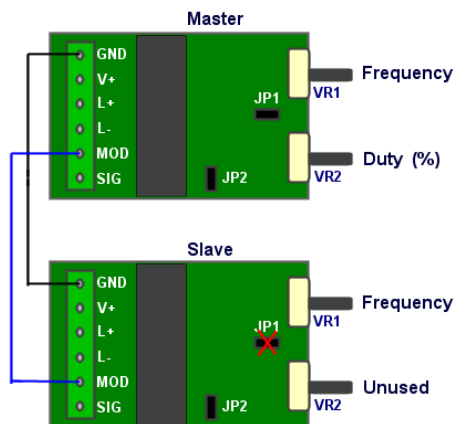

### Master controlled Duty with independent Frequency control

Modules linked in this way will have independent frequency control while the duty percentage is controlled by the master device. This method can be useful for simultaneously driving reactive loads (such as transformers or capacitors) which have different impedances.

The 'MOD' connectors of two or more units are linked and the jumper JP1 is removed from whichever modules are to be a slave.

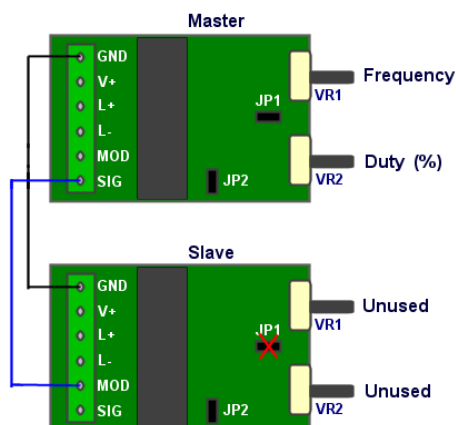

### Master Frequency and Duty with Opposite Phase

Two modules linked in this way will have the same output frequency but each signal will be of opposite phase. This means that when the output of master devices is on, the output of the slave device will be off and visa-versa. Changing the duty setting using the master control will alter which module is on longest. It can be adjusted fully between 50% each to either module having 100% while the other has 0%.

The 'SIG' connector of the master device is connected to the 'MOD' connector of the slave device and the jumper JP1 is removed.