

3 Channel Time Delay Generator

Simple phase or delay control for pulsed signals

Model: TD-3C

Type: 3 Channel, 2MHz, Schmitt trigger input

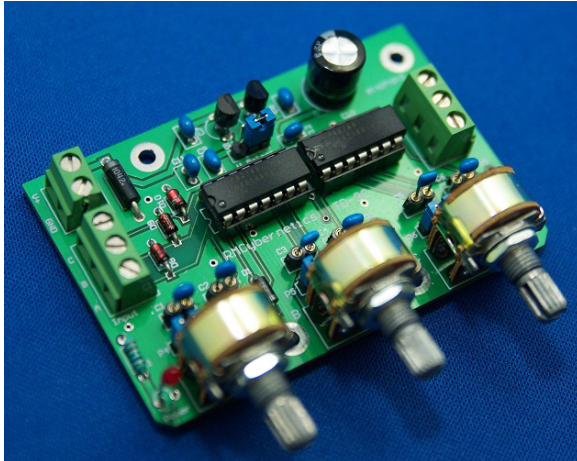

Features and Specifications

- Wide supply voltage range (12V – 30V)
- Selectable 12V or 5V logic output
- Schmitt trigger buffered inputs
- Three independent channels
- Delays from 250ns to 10s *
- Pulse width and pulse delay adjustment **
- High quality double layer PTH PCB
- Dimensions: L81 x H25 x W53 mm (pots +17 mm)

* Adjustable range determined by timing capacitor fitted to sockets. (See Table 2)

** Requires external potentiometer for pulse width adjustment

The **TD-3C** is a small time delay generator with 3 channels that can be used independently or linked together in a variety of ways. It can be used to create adjustable time delays in pulsed signals, or to split a signal to make multiple copies with an adjustable phase relationship between them. It is also possible to have different start and stop delays therefore changing the width of the pulse. As with other Cyber Circuits from RMCybernetics, the circuits can be daisy chained or linked with other circuits. The circuit is made in England on a high quality PCB with double layer design, plated thru holes (PTH).

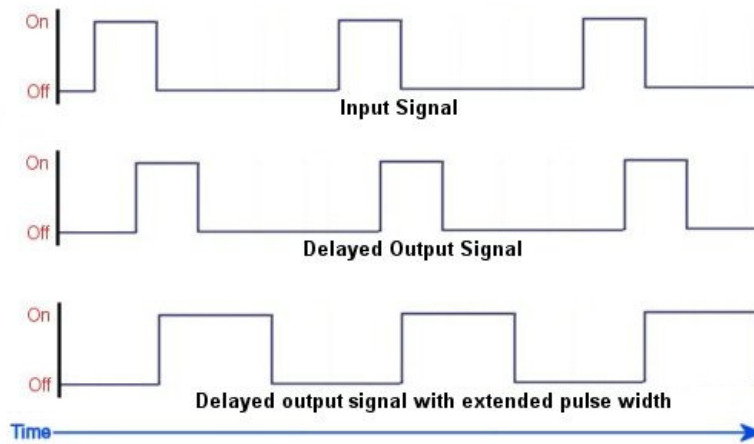

Fig 1: Example waveforms

Example Applications

- Convert sine/triangle waves or noisy waveforms to clean square signals.
- Add adjustable duty (pulse width) to an existing signal.
- Control the phase relationship between up to four signals
- Control circuit for linear magnetic accelerators
- Interferometry and resonance experiments

ELECTRICAL CHARACTERISTICS

NB: Figures may vary under different loading conditions and environments.

Symbol	Parameter	Min	Max
V_{in}	Input Supply Voltage	5V	30 V ¹
I_{sup}	Supply Current	10 mA	50 mA
I_{out}	Continuous Output Current	-8.8 mA	8.8 mA
f	Frequency input	0.01 Hz	2 MHz
t_{on} / t_{off}	Switching transition speed (rise / fall time)	40 ns	200 ns
SIG _{out} (HIGH)	Signal Output Voltage (High)	4.95V	11.95V
SIG _{out} (LOW)	Signal Output Voltage (Low)	0V	0.05 V
SIG _{in}	Signal Input	0 V	12 V

Table 1: Electrical Characteristics

¹ Input voltage is clamped by 5W, 30V Zener diode.

Connections

The main connections to the circuit are made using the terminal blocks at either end of the board. The input power (V_{in}) is connected to 'V+' with 'GND' connecting to ground or battery negative terminal. The signal inputs and outputs connect to the terminals A, B, and C.

The timing capacitors are fitted to the sockets marked C1 to C6. An external potentiometer for extending pulses can be connected to the jumper pins P4 to P6.

If connecting the signal inputs or outputs to the supply voltages, you should add a resistor of at least 100 ohms in series for protection.

The channels can be daisy chained on the same board or with other boards so that longer delays, or linked delays can be achieved. A series resistor is not required; you can simply connect an output of one channel to the input of another.

It is also possible to connect the inputs together so that you will get three copies of the input signal on the outputs, each with independently adjustable delay.

The TD-3C can be connected directly to the 'SIG' I/O terminals of our PWM-OCX and PWM-OCXI power pulse generators so that they can be made to pulse together with an adjustable delay between them.

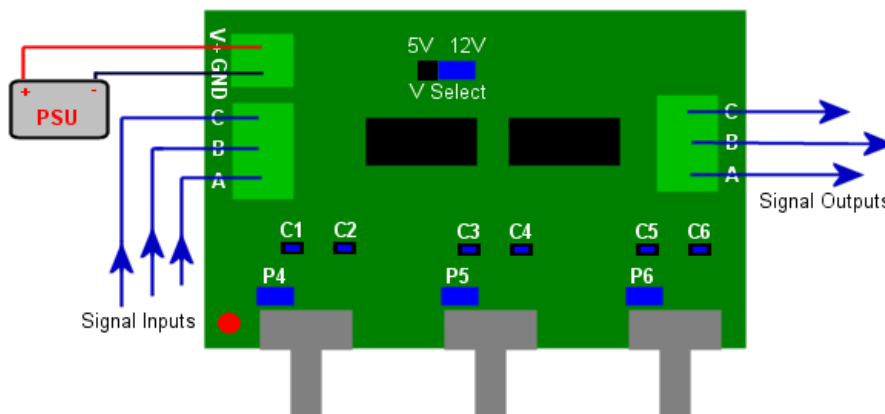

Fig 2: Typical connections for power and I/O

Jumper Settings & I/O connectors

V Select *Logic voltage level selection*

This is used to set the operational voltage level to either 5V or 12V so that it can be matched to the circuits that will interface with it. In the rightmost position (default), 12V will be used. To set 5V operation, remove the jumper link and replace it so that the two leftmost pins are connected.

P4 to P6 *Pulse width adjustment*

To increase the length of the pulse on any channel, remove the corresponding shorting link, and connect a resistor or potentiometer between the two pins. Typically a 1k to 1M pot will be used. Larger values will give longer times. You can connect two potentiometers of different values in series to give a 'coarse' and 'fine' adjustment.

C1 to C6 *Timing capacitors*

These sockets allow you to fit timing capacitors that will set the delay times. In most cases you would use a pair of identical capacitors for each channel, but you can also use ones of different values. Using different values would mean that the start and stop delay times were different and therefore the pulse length could be longer or shorter than the original input signal. See *table 1* for reference of capacitor values vs. delay times.

Important Usage Notes

- Do not exceed the selected logic voltage level at the signal inputs.
- Signal input voltages that are significantly lower than the selected logic level may affect the duration of the delay.
- Do not remove the timing capacitors, or change the logic voltage when the unit is powered on.
- The outputs are for logic only; they will not directly drive a load such as a motor or light.
- When using these with our PWM-OCX or PWM-OCXI, make sure the 12V logic level is selected.
- Circuits interfacing with this unit must all share a common ground connection (i.e. all powered from the same battery).
- The length of the input pulse must be longer than the length of the delay setting otherwise the output will remain low.
- The delay times are different when operating at 5V than at 12V.
- Timing capacitors provided can have a tolerance of +/- 20%. As they are used in pairs the variation between capacitors can cause the delay for the start and end of the pulse to be slightly different and therefore alter the pulse width. If you need more precision, you should use low tolerance capacitors or find a matching pair by measuring them.

Controls

The three potentiometers marked A, B, and C will adjust the delay on channels A, B, and C respectively. Turning the control clockwise will increase the delay.

Capacitor Values and Corresponding Delay

By fitting different sized capacitors into the sockets marked C1 to C6, a wide range of delay times can be achieved. The table below gives some example values and the corresponding delays produced. You can use any other capacitance you desire to get other ranges. If you use polarised capacitors, ensure the negative terminal is to the left side of the socket. The "Max Frequency" in the table below shows the maximum input frequency of a signal with 50% duty that will still allow you to adjust the delay with a full rotation of a control knob. Higher input frequencies (or shorter pulses) will cause the output to go low.

These values are measured under typical operating conditions and may vary due to capacitor tolerance.

Capacitance	Max Frequency	Minimum Delay	Maximum Delay
1uF	20 Hz	1 ms	24 ms
220nF	100 Hz	0.16 ms	4.9 ms
10nF	2 kHz	9.7 us	0.25 ms
1nF	20 kHz	1.2 us	25 us
220pF	90 kHz	480 ns	5.7 us
100pF	200 kHz	350 ns	2.6 us
22pF	>2 MHz	250 ns	290 ns

Table 1: Capacitor values for delay ranges (12V operation).

Capacitance	Max Frequency	Minimum Delay	Maximum Delay
1uF	18 Hz	2.3 ms	27 ms
220nF	70 Hz	0.5 ms	6.6 ms
10nF	1.7 kHz	25 us	0.28 ms
1nF	17 kHz	3.3 us	29 us
220pF	70 kHz	1.2 us	7.5 us
100pF	160 kHz	950 ns	3.7 us
22pF	>2 MHz	700 ns	800 ns

Table 1b: Capacitor values for delay ranges (5V operation).