

Power Pulse Modulator

A High Performance Versatile Square Pulse Generator

Model: PWM-OCXi v2

Type: High Voltage, 9A, 500V, 1.5MHz, Active Protection

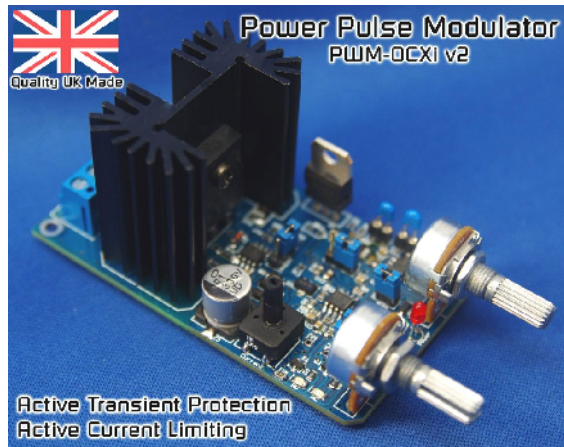

Features and Specifications

- Advanced active voltage and current protection
- Wide supply voltage range (12V – 30V)
- Transient voltage tolerant to 500V
- Standoff voltage from 0 to 340V
- Max output current 9A* continuous, 120A peak
- Latest low voltage drop IGBT technology
- Frequency range 0Hz to 1.5MHz **
- Pulse width adjustable between 0% and 100%***
- Adjustable current limit / constant current mode
- I/O connections for logic interfacing
- Pulse width can be set as percentage duty, or as a specific pulse time.
- Highly compact design
- High quality double layer PTH, 2oz Copper PCB
- Dimensions: L85 x W46 x H44 mm (pots +21mm)

* Max current varies with frequency due to switching losses. (See figure 0)

** Full frequency range requires fitting capacitors (not included) to onboard socket. No soldering required (See Table 2)

*** Duty not adjustable to 100% at the top frequency ranges unless using monostable mode.

The **PWM-OCXi v2** is an advanced adjustable DC pulse generator designed for providing an easy way to adjust power to devices or to pulse them at a wide range of frequencies and pulse times. The frequency is independently adjustable to the pulse width which can be varied smoothly from 0% to 100% or set to be a specific pulse time. It is designed to fit a wide range of applications and be fully adjustable so that it can be used for many different tasks. The **OCXi v2** is designed primarily for use in high voltage circuits such as for driving high voltage coils or any circuit where a significant amount of back EMF or transient voltage must be tolerated. The new built in current limit adjustment is ideal for automatically limiting motor stall current, or transformer input current when loading is variable.

Many devices such as coils will have dynamic impedance and transient feedback levels when being pulsed from an adjustable frequency circuit. The OCX v2 and OCXi v2 have advanced protection circuits that continuously monitor the output current and voltage. If any conditions are detected that might exceed the ratings of the unit, the output will momentarily be disabled or chopped so that the transient voltages or currents are reduced. During any of these fault conditions an LED will illuminate to indicate that the protection circuit is active and affecting the output. There are also I/O ports for monitoring or manually triggering the protective circuits.

The PWM-OC range of PWM circuits are highly compact and have been built so that they can easily be incorporated into projects requiring some pulsed power control. The circuit is made in England on a high quality PCB with double layer design, plated thru holes (PTH), and 2oz copper (twice as much as standard circuits) for durability and performance.

Example Applications

- Flyback Transformer Driver
- Ignition Coil Driver
- Induction Heating
- SSTC (Tesla Coil)
- DC-DC converters, inverters, and SMPS
- Solenoid or Valve Control
- Resonant Energy or Magnetic Pulse Experiments
- Fluorescent and Neon lighting control
- Motor or Fan Speed Control & Soft Start with stall current limiting
- Ultrasonic Transducer Driver
- And more...

Glossary of terms – Explanations of some terms used in this document

Load

The device such as a motor or light that is to be pulsed by the circuit. This would be connected between L+ and L-.

Supply Voltage

This is the safe voltage range that can be applied to the input terminals GND and V+ for proper operation of the device.

Switching Voltage

This is the maximum voltage that will be momentarily tolerated between the L+ and L- output terminals. The circuit does not directly generate this voltage, but inductive loads (coils) or external secondary power supplies may be capable of producing high transient feedback voltages that are much higher than your supply voltage. The OCX* v2 circuits will limit this voltage so that transient voltages above the switching voltage do not occur.

Maximum Standoff Voltage - This is the maximum voltage that can be applied as a secondary supply without beginning to trigger any voltage protection circuits.

Switching Speed – The small time taken for the transition between off and on or visa-versa when applying pulses to a load.

Quick Usage Guide

The PWM-OCX* v2 range are designed to be highly versatile while still remaining simple to use. This quick usage guide will help you to quickly get started with the circuit and help you to make the most of the advanced features. We also recommend that you read this datasheet in full and check out the product usage guides on our website.

Power Input

Use a power supply that is capable of delivering at least the peak current that your load device will draw from a DC supply. For example; a motor with 1 ohm DC resistance being powered from a 12V input will need a 12V PSU capable of delivering at least 12A current (calculated using ohms law). If you try to use a PSU with a lower current rating, the supply to the internal electronics of the OCX* v2 will be unstable and might not be able to operate correctly or protect its self from overload conditions. See our product tutorial “Power Supply Considerations” on the website for more information.

Load device

Consider Ohms Law and the maximum rating of the circuit for the frequency at which you want to operate. Inductive loads such as coils will generate significant transient voltages which will be limited by the circuit. These transients will activate the protection circuits and interrupt the frequency setting you might be trying to use. You can avoid this entirely by placing a fast diode in parallel with your load device. See the product tutorial “Driving Inductive Loads” for more details.

Start-up and Controls

When first using our OCX* v2 circuits we suggest that set the current limit adjustment to minimum (fully anticlockwise) before powering up the device. Practice adjusting the duty and frequency controls while observing the response of the HV and HC LED indicators. Ideally you should also observe the actual average current flow using a DC ammeter as this will help you to get a good feel for how your load and circuit respond to the adjustment of the controls.

The current limit should be set no higher than is needed for your application as this will offer maximum protection against accidental damage to the circuit or load device. The maximum setting (fully clockwise) for the current limit is approximately 67A which is much more than the rated DC average current of the circuit. This high upper limit helps to allow for operation where you need a large peak current with a very low duty cycle, or for intermittent use which will not cause excessive heating in the circuit. For most situations the current limit control should be turned only slightly past minimum which should allow for a good current flow while maintaining good overload protection.

If you know the frequency range in which you wish to operate the device, choose a timing capacitor (inserted into C1) that will offer the bulk of your desired frequency at the low end of its range. In the most anticlockwise positions, the frequency adjustment control is less sensitive and allows for more precise adjustment which is why you should try to choose your capacitor to suit.

Power Dissipation

The power dissipated as heat in the main switching transistor can vary significantly with different loading conditions and control settings. The device will operate much more efficiently at lower frequencies (<10kHz) and will not heat up significantly. If you need to operate at higher frequencies, you should consult the graph in *figure 0* and set the current limit accordingly to prevent overheating. There is no built in thermal overload protection but this can be added easily if desired.

The circuit has been designed so that you can add thermal protection to the transistor, or even your load device very simply. By using an NTC thermistor, or a thermal fuse type sensor, you can automatically deactivate the output when an excessive temperature is detected. When the device cools again, the circuit output will automatically activate again. Your temperature sensor should be connected such that it would pull the EN pad low (i.e. between EN and GND). A resistance of 13k ohms or less between EN and GND should be sufficient to disable the output power. The temperature sensor you use should be well fixed to the heatsink of the circuit or to the part of your load device which will be getting hot. You can find more information about adding thermal protection in our product tutorials on our website.

ELECTRICAL CHARACTERISTICS (MAXIMUM RATINGS)

NB: Figures may vary under different loading conditions and environments. Ratings are based on test conditions of 13.8V input and wire wound resistor load impedance of 0.5 ohms

Symbol	Parameter	Min	Max
V_{in}	Input Supply Voltage	12V ¹	30 V ²
V_{out}	Output Voltage	-	$V_{in} - V_{drop}$
V_{soff}	Maximum Standoff Voltage	0V	340V
V_{sec}	Secondary Switching Voltage	0 V	500 V
I_{sup}	Supply Current (no load)	20 mA	250 mA
I_{out}	Continuous Output Current	0 A	9 A (20 A with fan)
I_{pulse}	Pulse Current (1ms, 25C)	-	120 A
I_{adj}	Current Limit Adjustment	500 mA	67 A
f	Frequency	DC (0 Hz)	1.5 MHz ³
t_{on} / t_{off}	Switching Speed (no load)	16 ns / 20 ns	32 ns / 52 ns
t_{on} / t_{off}	Switching Speed (load)	16ns / 20 ns	128 ns / 100 ns
V_{drop}	Output Voltage Drop (varies with output current)	1.9 V	2.4 V
SIG_{out}	Signal Output (high)	4.8 V	5 V
SIG_{in}	Signal Input	0 V	5.5 V
PWM_{out}	PWM Control Voltage Output	1.2 V	3.2 V
PWM_{in}	PWM Control Voltage Input	0 V	5 V
FM_{in}	Frequency Modulation Voltage Input	0 V	5 V
OSC_{out}	Oscillator Logic Output Voltage (high)	4.8 V	5 V

Table 1: Electrical Characteristics

¹ Units will still oscillate when powered by a supply voltage as low as 5V but the heating in the transistor will increase significantly (and therefore reduce current capacity)

² If operating at higher than 20V and at maximum frequency (or drawing >200mA unloaded), additional heatsinking will be required for 12V regulator U1.

³ The oscillator can be made to run at up to approximately 2 MHz, but doing so will risk overheating the control circuit components.

Power Ratings

Test conditions (See Fig 0b):

13.8V input, 0.5 ohm load (wire wound resistor) (R1), 1000uF power capacitor (Cp).

The **PWM-OCXI (v2)** continuous current rating is based on the temperature increase of the components. The ratings given are for the maximum average current possible before any component (typically the switching transistor T1) reaches 100°C (+/- 5°C) and is no longer increasing in temperature.

To use the circuit at full power, you need to check against this graph the maximum current you can set for your working frequency. You will also need to fit a large capacitor at the input terminals.

This graph is valid for the test conditions described. In your application, the performance may vary above or below what is shown here. The graph also shows power ratings when the unit is cooled with an external fan. The fan used was a 40mm, 5.7CFM DC fan connected to the onboard 12V fan connection point.

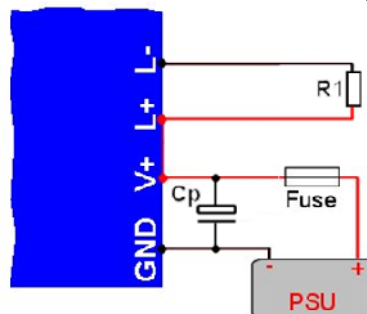

Fig0b: PWM-OCX Test Circuit

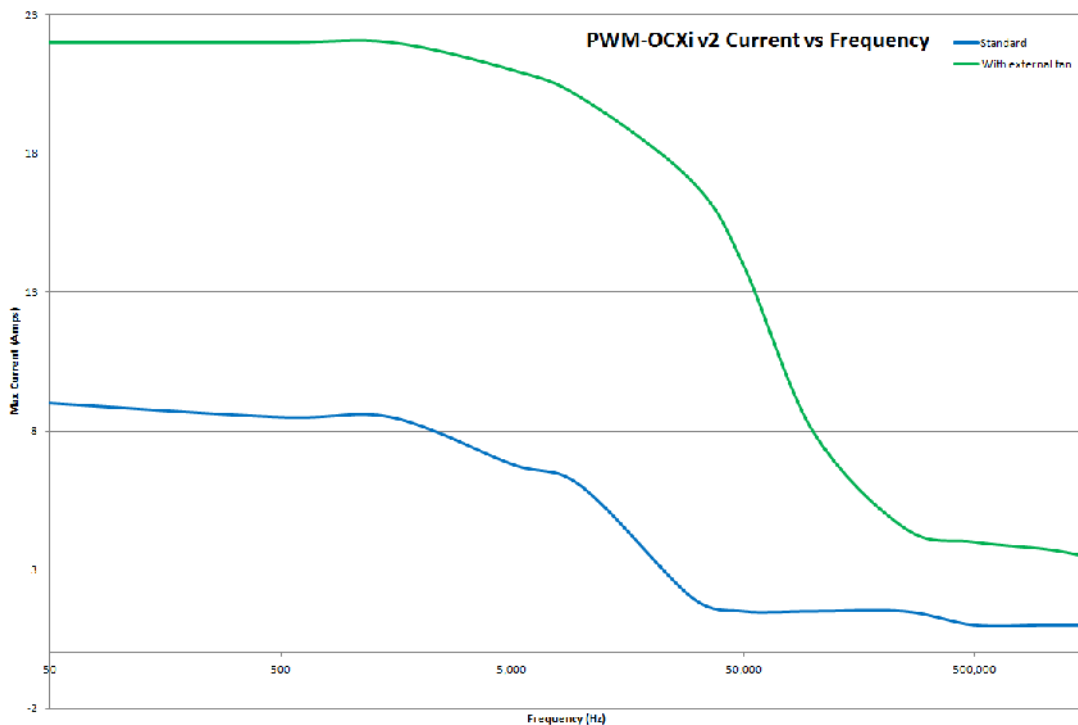
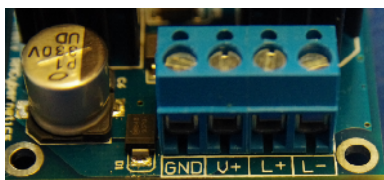

Fig0: PWM-OCXi v2 Current vs. Frequency

Connections

The main connections to the circuit are made using the 4-way terminal block at the end of the board. The input power (V_{in}) is connected to 'GND' and 'V+', while the load is connected between L+ and L-. See the diagrams below for how to connect a secondary supply. Some other connections such as OSC and FM can be made using the solder pads provided on the PCB. See the specs above and below for further details.

If you intend to pass large currents, ensure that the wire used is thick enough and that a sufficient capacitor is placed at the power input (see Fig0b). Always use a fuse to protect the circuit from accidental overloads or short circuits.



GND	Ground, Earth, 0V, or battery negative terminal.
V+	Input Supply Voltage, or battery positive terminal
L+	Load positive (internally connected to V+)
L-	Load negative

Fig 1a: Terminal Connections

Power Connections

Below you can see typical connections for the power supply and load. Make sure the cables are thick enough to carry the current you want to pass, and keep them short if possible. It is possible to use a single supply to power both the circuit and your load (see fig 2), or you can use a separate secondary supply for the load. This allows you to supply a different voltage to your load than what you are using to power the circuit. For the **PWM-OCXi (v2)**, this secondary voltage can be from 0V to 340V.

Output Load Considerations

The minimum load impedance that should be connected to the device can be calculated using ohms law. Connecting loads with lower impedance could damage the circuit;

$$R_{LOAD} = V / I_{pulse}$$

For Example:

Using a 12V supply, $R_{LOAD} = 12 / 120 = 0.1$ ohms

If you connect a load with a lower impedance than calculated like this, the active current limit circuit may not be able to prevent the main transistor from being destroyed.

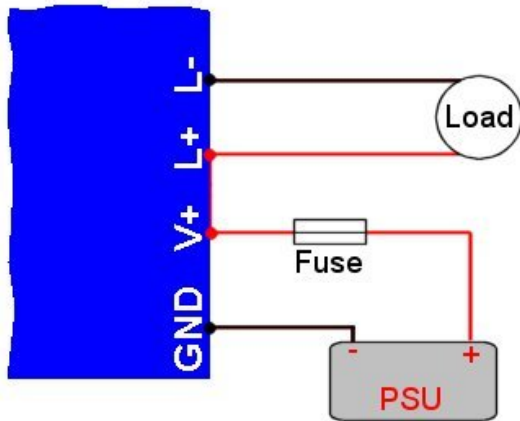

Fig 2: Typical power connections

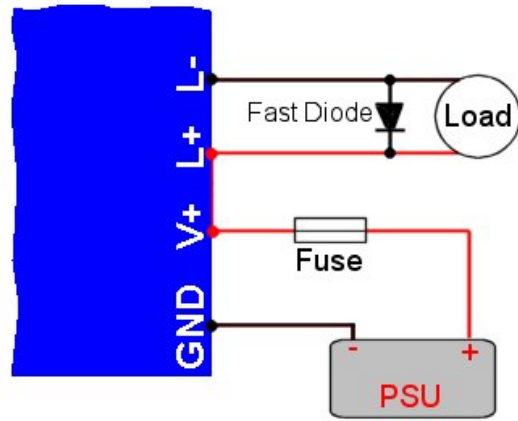

Fig 3: Typical power connections for inductive loads

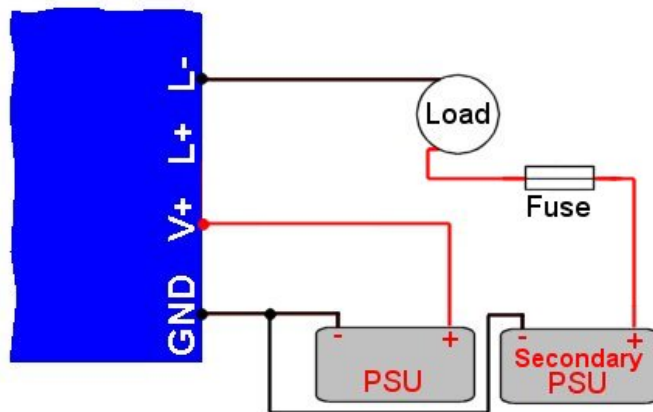

Fig 4: Typical power connections with secondary supply

Active Voltage and Current Limiting

The onboard current limiter continuously measures the current flowing through the output. The measured current is averaged over about 20ms so that large, brief peak currents can be supported while keeping the overall average current within safe levels. You can adjust the current limiter using the onboard control from anywhere between around 0.5A to 67A. It is important that you consider the peak currents that could occur in your setup and to ensure that they will not exceed the rated peak current of the device. If the peak current exceeds rated levels, the current limiter may not activate soon enough to prevent the main transistor from being destroyed. If necessary, it is possible to alter the length of time over which the current is averaged. For longer averaging time, you can either replace C10 with a larger value or connect a capacitor between HC and GND. Making modifications to the protection circuits is not recommended and is done at your own risk. If you would like faster response or shorter averaging, it would be necessary to remove the surface mount capacitor marked C10 or to replace it with one of a lower capacitance (<220nF).

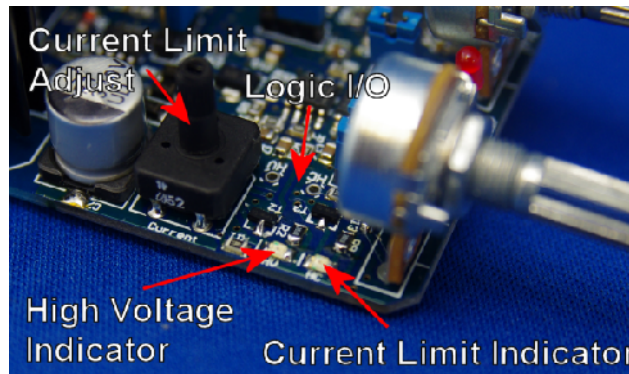

Fig 5: Active protection circuits

There are both active and passive transient voltage protection circuits in this device. The passive protection consists of a pair of TVS diodes which have very rapid response time but will dissipate transients as heat. To prevent these overheating, the active protection will measure the transient voltages and average them over about 30ms. If the averaged transient voltage level is too high then the output will be momentarily disabled until the voltage level drops down again.

When either the HV or HC protection circuits activate, the output is briefly disabled until a safe condition is established. This will have the effect of chopping or modulating the output waveform so that the averaged readings are within safe limits.

Jumper Settings & I/O connectors

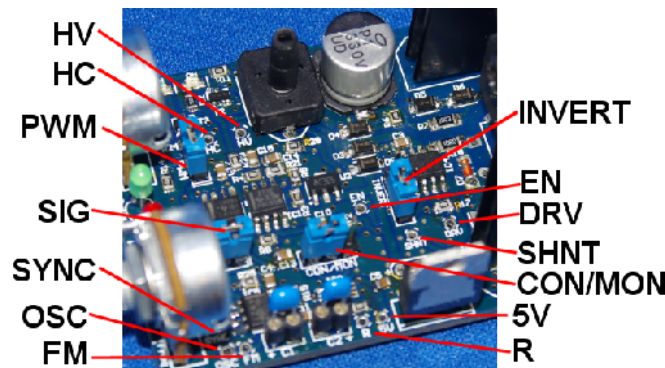

Fig 6: Jumper & Solder Connections

SIG *Oscillator signal in/out*
 The jumper SIG is used to connect the internal oscillator to the rest of the circuit. With the SIG jumper link in place the device will function from the onboard signal. With the SIG jumper link removed, the device will require an external pulse signal to be applied to the SIG pin at the side marked with a stripe. The OCX units have a Schmitt trigger input which means the

output will be square wave regardless of the input waveform. More information about linking modules together can be found on the next pages.

PWM *PWM voltage in/out*

The jumper shown as PWM can be used in a variety of ways for altering how the duty cycle (pulse width) is controlled. In its default position the pins are connected and duty control is done using the on board potentiometer. To control duty cycle with an external voltage the PWM jumper link is removed and the input voltage is applied to the PWM pin at the side marked with a stripe. The output duty is inversely proportional to the input voltage. 1.6V will give 100% duty while 3.5V will give 0%. You can use any voltage between these values to set the duty to a desired level.

INVERT *Invert Output*

The position of this jumper determines if the output is a matched or inverted form of the oscillator signal. In the default position, the output pulse matches the input or oscillator pulse. Moving the link towards the INVERT marking will set the output to be inverted. In the inverted state, the Duty (%) control would be reversed so that fully clockwise would be 0% output. Note that the 5V level output from the SIG jumper would not be inverted. The DRV voltage level will be up to 12V when in the inverted state.

CON/MON *Continuous or Monostable operation*

The position of this jumper link will determine how the output duty is generated. In the default position (CON), the output duty can be adjusted using the onboard duty potentiometer and will be set as a percentage between 0 and 100% of an oscillator cycle. If the link is moved to the MON position, the length (on time) of the output pulse will always be at the value you set regardless of any frequency adjustment. To do this you must connect an external resistor or potentiometer between 5V and R so that adjusting this resistor will adjust the length of the output pulse. When using monostable mode, the onboard duty control should be set somewhere above 0% as setting this to 0% will also disable the monostable pulse. See table 3 for capacitor and resistor combinations and corresponding pulse lengths.

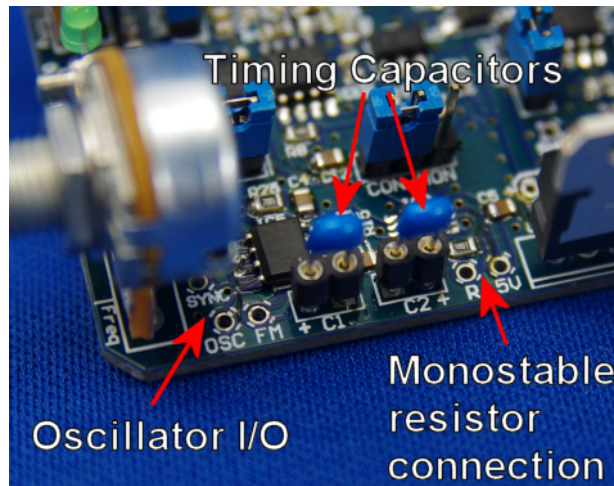

Fig 7: Connections for timing capacitors and resistor

DRV *Drive Signal*

This solder pad can be used to monitor the internal signal before it is amplified for driving the main transistor. This signal will normally be 0-5V but will be at 0-12V when the INV jumper is set to invert the output. This point is useful for monitoring the internal signal as it will not be interrupted by any fault conditions (unless inverted). Note that this signal may appear more rounded than the final output pulse as it will be amplified later.

EN *Enable/Disable*

This connection is used to enable or disable the output power. By default the EN terminal is held high and thus the output is enabled. The onboard protection circuits will pull this low during any fault conditions. When high, the EN terminal is held at 12V so if you need to link with a microcontroller you may need to use a small transistor or voltage divider. You can also use this for connecting a switch for easy on/off control of the output without powering down the whole circuit. The EN terminal is ideal for connection to additional sensors for protecting the circuit or your load. For example you can connect an NTC thermistor between EN and GND so that when the temperature increases, the device output will be disabled until it cools again. For the output to be disabled, the resistance between EN and GND should fall below around 13k ohms.

SHNT *Shunt Voltage*

This is a direct connection to the 750uR shunt resistor which is used to monitor current flow. This can be useful for connecting to external ammeters or ADCs which are made to measure current using a 750uR shunt.

FM *Frequency modulation input*

This solder pad is for connecting an external control voltage for modulation of the output frequency. The voltage should be between 1.7V and 5V. When using the modulation input, the output duty may also increase when the frequency increases.

OSC *Oscillator output*

This is the square wave output from the oscillator. It can be used as a reference signal for monitoring frequency as the output is not affected by the duty setting.

HV *High Voltage Protect*

This connection will output a voltage pulse which is proportional to the level of excess transient voltage at the power output. The voltage can vary between 0V to 4V. You can also use this terminal to disable or adjust the level of transient protection. Connecting this to GND will disable the active transient voltage protection. Pulling it high will force the protection circuit to activate and disable the output power. You can also connect a capacitor between this terminal and GND to increase the length of time over which the transient pulses are averaged. This would mean that larger transients would be allowed to occur and that the passive transient protection could increase in temperature beyond design limits.

HC *High Current Protect*

This connection will output a voltage pulse which is proportional to the level of excess current above the limit set by the current adjustment control. The voltage could be from around 0V to 3V. Connecting this to GND will disable the active current limiting. Pulling it high will force the protection to activate and disable the output power. You can also connect a capacitor between this terminal and GND to increase the length of time over which the current is averaged.

C1 *Oscillator Timing Capacitor*

This socket allows you to fit the timing capacitor of your choice. See table 2.

C2 *Monostable Pulse Width Timing Capacitor*

This socket allows you to fit the timing capacitor of your choice. See table 3

FAN *Optional connection for 12V Fan*

This is simply a connection to the onboard 12V regulator which can be used to supply power to a fan. Note that using this may increase the temperature of the regulator if your input voltage is over 20V. You should not draw more than 200mA from this connection.

Important Usage Notes

- Always make sure the pulse width is set to minimum (pot turned fully anti-clockwise) before connecting the circuit to a load or power source.
- Use a fused power supply to protect from accidental short circuit or overload. The fuse should be rated to suit your application and up to a maximum of the units specified pulse current. Use a quick blow type fuse.
- The heat generated in the switching transistor will vary with your loading conditions and the settings for frequency and pulse width. You should use the current limit adjustment to set an acceptable limit for your application and to keep the device from overheating.
- Ensure an adequate power capacitor is fitted between V+ and GND if you are using a single power supply. See Figure 0.
- Do not remove the timing capacitor C1 or C2 when the unit is powered on.
- When using voltages above 30V or when driving high voltage coils, you should make sure the GND connector and the metal parts of the control pots are suitably earthed for safety. Failure to do this risks damage to the circuit and and/or electric shock. You should not touch the circuit when it attached to a high voltage source as many of the component parts, including the heat sink will be live. You must also place plastic knobs on the controls for added safety.
- If you intend to make new connections to the I/O solder pads often, it is recommended that you fit pin headers so that the pads will not become damaged when desoldering wires.
- The PWM-OCX* range of devices are designed to hard switch the output transistor to give very fast rise and fall times. Under some conditions this may cause some unwanted ringing at the edges of the pulses delivered to your load. If you need to

reduce these, you can replace the gate drive resistor (R18) in the circuit with one of a larger value. The fitted resistor is 10 ohms so replacing this with one of a higher value will slow the switching time and could reduce ringing. This reduced switching time can increase switching losses at high frequencies so the value chosen must reflect a compromise between reduced ringing and increased switching loss.

- At very high frequencies or with very low impedance loads, the green output LED may not illuminate with a brightness proportional to the output duty. It may appear to be either on or off, or might not illuminate at all. You can confirm the actual output duty using an oscilloscope.

Controls

The frequency and duty cycle can be independently adjusted using the large potentiometers labelled 'Freq' and 'Duty'. The frequency is adjusted with 'Freq' while the pulse width can be adjusted with 'Duty'. Turning the control clockwise will increase the value corresponding function. The frequency range of the device depends upon the capacitor value of C1. The pre-fitted capacitor is 10nF which gives a range of medium frequency pulses which are suitable for most applications. Replacing C1 with a larger value capacitor will give a range of lower frequencies. At very low frequencies the green output LED will flash for a time that is proportional to the frequency and pulse width setting.

The small potentiometer marked 'Current' is used to set the output current limit. When fully clockwise the limit is set to a maximum of around 67A. Turning the control anticlockwise will reduce the threshold at which the output will be chopped in order to maintain the current limit. When fully anticlockwise the minimum current limit setting is around 0.5A. When the current flow is below the set threshold the duty control will operate normally. When the output current exceeds this threshold, then further increasing the duty control will increase the amount of time the chopping circuit is active but will not increase the average current.

Capacitor Values for C1 and Corresponding Frequency

By fitting different sized capacitors into the socket marked C1, a wide range of frequencies can be achieved. The table below gives some example values and the frequency range produced. You can use any other capacitance you desire to get other frequencies. Note that the values shown will allow the unit to oscillate above the specified frequency range, but these are for reference only. As the frequency increases, the output will become more rounded and the transistor may not switch fully on during each pulse. This can lead to excessive heating which could potentially damage the unit. Using the device above its rated top frequency is done at your own risk. See Fig0 for how frequency affects heating. If using a polarized capacitor check the markings on the PCB for the correct orientation.

Capacitance	Min Frequency	Max Frequency
1uF	1Hz	200Hz
0.47uF	1.5Hz	400Hz
0.33uF	2Hz	600Hz
220nF	3Hz	1kHz
10nF	219Hz	21kHz
1nF	710Hz	175kHz
220pF	3kHz	546kHz
100pF	6kHz	925kHz
22pF	19kHz	1.7MHz

Table 2: Capacitor values for frequency ranges.

Capacitor Values for C2 and Corresponding Pulse times in monostable mode

By using different resistor capacitor combinations for R and C2, you can see a wide range of pulse times for the monostable mode of operation. We recommend using a 10k potentiometer for R and then use the table below for selecting a suitable capacitor. You can also use other values for R. A lower value potentiometer will give a smaller adjustment range which can

allow for more precision in a specific range, or a larger potentiometer will give a broader range of adjustment. If using a polarized capacitor check the markings on the PCB for the correct orientation.

Capacitance (code)	Min Pulse Width	Max Pulse Width
1uF (105)	1ms	10ms
220nF (224)	235us	2.3ms
10nF (103)	10us	0.1ms
1nF (102)	1.1us	11us
220pF (221)	312ns	2.9us
100pF (101)	160ns	1.5us
22pF (22J)	76ns	540ns

Table 3: Capacitor values for pulse widths in monostable mode (using a 10k potentiometer for R).

Driving Inductive Loads (Motors, Solenoids, Transformers, Relays, Coils, etc)

The **PWM-OCXi v2** has advanced protection against high voltage transients from inductive loads. This unit is suitable for use with ignition coils and other high voltage coils. The active protection circuitry will prevent transients from damaging the circuit. The protection circuits have been designed to be as robust and flexible as possible so that you can adjust the controls freely without worrying about damaging the circuit. You should still however pay attention to the warning indicators and try not to operate the device continuously with them lit. You must also take care to keep the current limit at the correct level for the frequency used to avoid overheating.

LED Indicators

The red power LED lights to indicate that power is present in the signal generation circuitry. This can also be used to indicate the overall health of your input power supply. If the LED dims when the PWM output is high, this indicates your power supply is struggling to provide enough current. This could mean a low battery or overloaded PSU. Note that running the unit in these conditions may cause it to overheat and will disrupt normal operation of the protective circuits.

The green output LED lights when the switching transistor is on and power is being delivered to the outputs. At low frequencies you will see it flashing, at higher frequencies it will appear to be on with a brightness proportional to the duty setting.

The two surface mount LEDs marked HV and HC will illuminate red to indicate that the protection circuits are actively limiting the output current or transient voltages.

Linking Modules

Multiple units can be linked in a number of different ways. A master/slave arrangement can be used so that both units pulse together or at different times and rates. The diagrams below show how to link modules together or to other devices. The connections for power and load are not shown for simplicity. It is assumed each module is connected to one or more power sources with a common GND. A load can be connected to an individual module, or all modules can drive a separate load each. Any changes to the jumpers and links should be done with all power switched off.

When linked in the ways shown below, it is possible to still use the monostable mode described earlier. If you set up the slave as monostable mode, the master will determine the frequency but the slave will always have the set pulse time determined by your monostable configuration.

The protection circuits will continue to work independently in each module when linked.

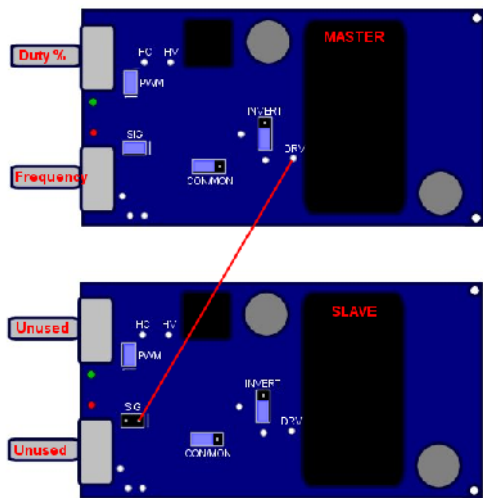

Master controlled Frequency and Duty

Modules linked in this way will all output the same frequency and duty which is set by the controls on the master device. You can have any number of slaves in this setup, as the signal is boosted in each unit.

The 'SIG' jumper link from the slave device should be removed and then a wire should be connected between DRV on the master unit, and the input pin of the SIG header as shown.

If you wish the slave's output to activate inversely, you can move the slave's INVERT jumper link to the INVERT position. This will make the slave off whenever the master is on and vice-versa.

Changing the duty setting using the master control will alter which module is on longest. It can be adjusted fully between 50% each to either module having 100% while the other has 0%.

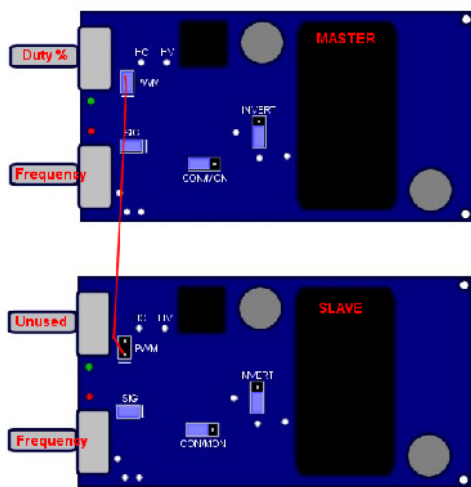

Master controlled Duty with independent Frequency control

Modules linked in this way will have independent frequency control while the duty percentage is controlled by the master device.

The 'PWM' jumpers of the slave units are removed, and then a wire is connected from the PWM link of the master to the input pin of the PWM header on the slave.

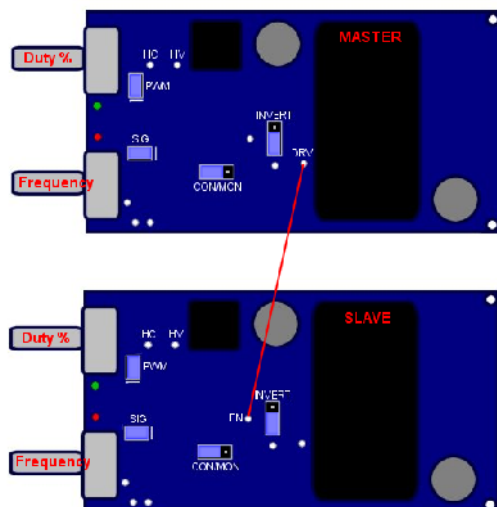

Gated or Modulated Slave

It is possible to modulate the output of a slave unit with another signal. This is often called Amplitude Modulation, or Gating. Typically you would set the master to a low frequency, and the slave to a higher one. When connected in this way, each time the master outputs high, the slave will be enabled. The slaves power output is therefore a sequence of high frequency pulses like shown below.

Connect a wire from DRV on the master to EN on the slave.

